

Hanging Brackets and Bracket Legs

Code HB (Hanging Brackets)

Code WBL (Bracket Legs)

80mm to 315mm

Material

2.0mm galvanised steel, 10mm hole

Sizes

80mm to 315mm diameter

Note

It is strongly recommended that Hanging Brackets and Bracket Legs be used every second length of duct.

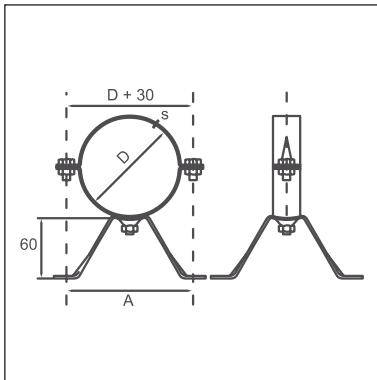

With legs

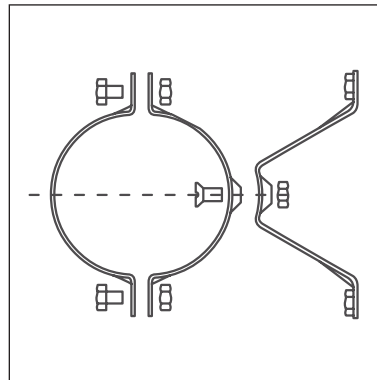

For wall mounting

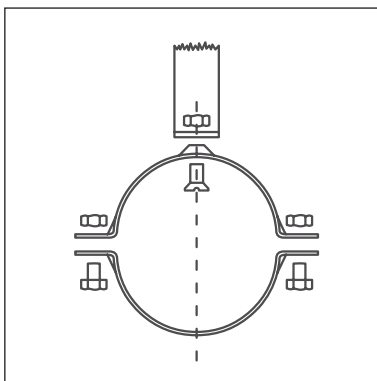

Suspended



Bracket Legs

Dimensional Specifications

D mm	A mm	S mm	Weight kg
80	132	2,00	0,10
100	132	2,00	0,12
120	132	2,00	0,15
125	132	2,00	0,16
140	132	2,00	0,18
150	132	2,00	0,20
160	132	2,00	0,22
180	210	2,00	0,24
200	210	2,00	0,26
225	210	2,00	0,28
250	210	2,00	0,30
275	210	2,00	0,32
300	210	2,00	0,34
315	210	2,00	0,35

